



ES-50 Parts Manual

American Dryer Corporation
88 Currant Road
Fall River, MA 02720-4781
Telephone: (508) 678-9000 / Fax: (508) 678-9447
E-mail: techsupport@amdry.com

www.amdry.com

Retain This Manual In A Safe Place For Future Reference

American Dryer Corporation products embody advanced concepts in engineering, design, and safety. If this product is properly maintained, it will provide many years of safe, efficient, and trouble free operation.

ONLY qualified technicians should service this equipment.

OBSERVE ALL SAFETY PRECAUTIONS displayed on the equipment or specified in the installation manual included with the dryer.

The following “**FOR YOUR SAFETY**” caution must be posted near the dryer in a prominent location.

FOR YOUR SAFETY

Do not store or use gasoline or other flammable vapors and liquids in the vicinity of this or any other appliance.

POUR VOTRE SÉCURITÉ

Ne pas entreposer ni utiliser d'essence ni d'autres vapeurs ou liquides inflammables à proximité de cet appareil ou de tout autre appareil.

We have tried to make this manual as complete as possible and hope you will find it useful. ADC reserves the right to make changes from time to time, without notice or obligation, in prices, specifications, colors, and material, and to change or discontinue models.

Important

For your convenience, log the following information:

DATE OF PURCHASE _____ MODEL NO. **ES-50**
RESELLER'S NAME _____
Serial Number(s) _____

Replacement parts can be obtained from your reseller or the ADC factory. When ordering replacement parts from the factory, you can FAX your order to ADC at (508) 678-9447 or telephone your order directly to the ADC Parts Department at (508) 678-9000. Please specify the dryer model number and serial number in addition to the description and part number, so that your order is processed accurately and promptly.

The illustrations on the following pages may not depict your particular dryer exactly. The illustrations are a composite of the various dryer models. Be sure to check the descriptions of the parts thoroughly before ordering.

“IMPORTANT NOTE TO PURCHASER”

Information must be obtained from your local gas supplier on the instructions to be followed if the user smells gas. These instructions must be posted in a prominent location near the dryer.

Table of Contents

Cabinet Diagram	4
Control Panel / Toe Panel	6
Rear Dryer Panel	8
Lint Box / Lint Screen	10
Blower Motor Assembly	12
Burner Assembly	13
Steam Coil / Electric Oven Assembly	14
Drive Motor Assembly	15
Sail Switch Assembly	16
Motor Contactor Panel	17
Fire Suppression System	18
Tumbler Wheel Assembly	19
Transformer Assembly	20

Cabinet Diagram

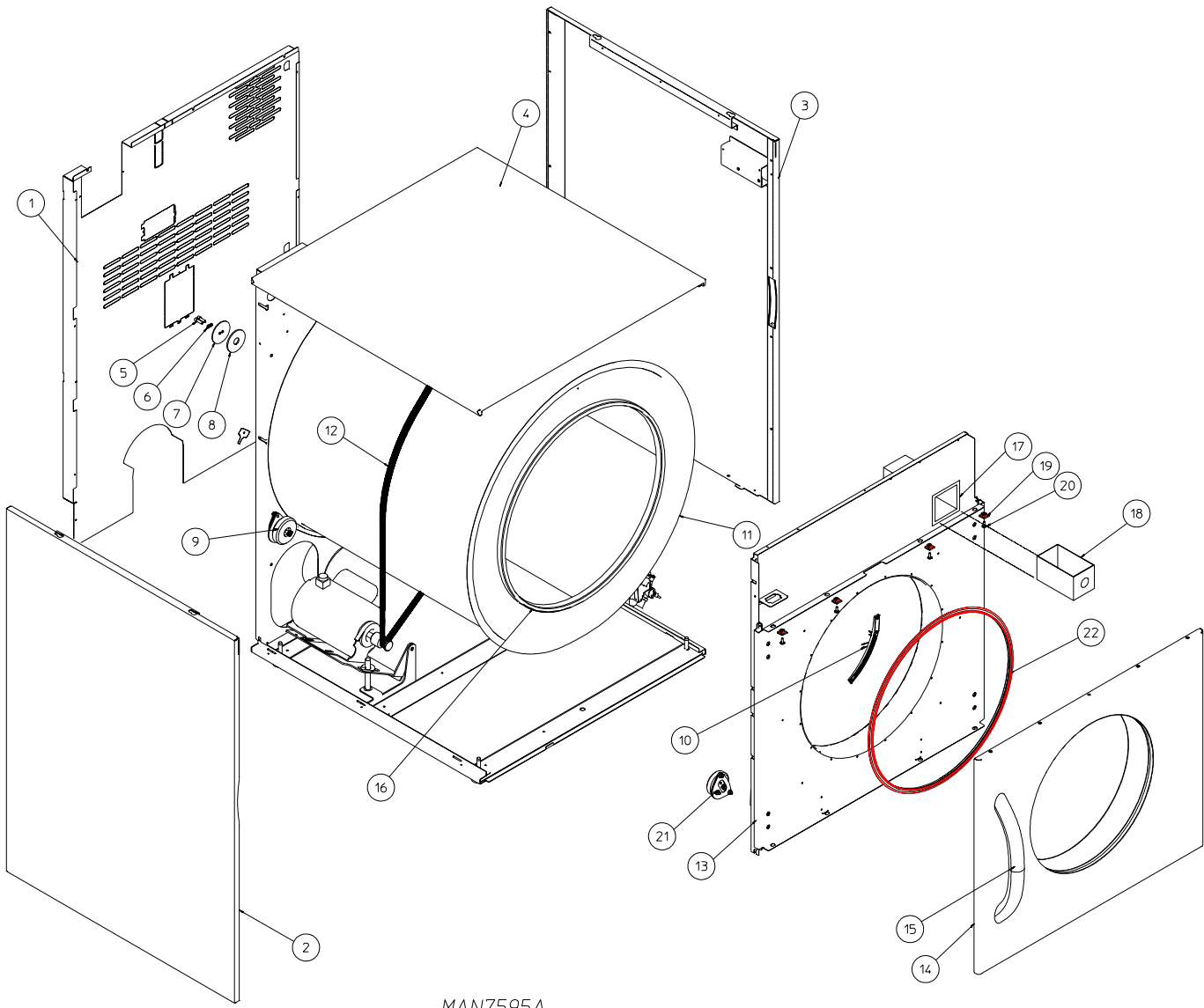

MAN7595A

<u>Illus. No.</u>	<u>Part No.</u>	<u>Qty.</u>	<u>Description</u>
1	822363	1	2-Piece Back Guard Assembly (gas and electric)
	822096	1	2-Piece Back Guard Assembly (steam)
	320674	1	Top Back Guard (gas and electric)
	323038	1	Top Back Guard (steam)
	323372	1	Bottom Back Guard
2	815081	1	Tall Left Side Panel Assembly
3	815082	1	Tall Right-Hand Side Panel Assembly
4	815077	1	Top Panel Assembly
5	153064	2	1/4-20 x 1/2" Socket Cap Screw
6	153072	2	1/4" High Collar Lock Washer
7	185426	1	Dual Screw Backup Washer
8	153048	2	Inner Friction Pad
	354217	1	3/4" Plate Spacer ... Not Illustrated
	185240	1	Extended Tumbler Shaft ... Not Illustrated
9	851530	2	Rear Wheel Bracket Assembly (refer to Tumbler Wheel Assembly on page 19)
10	819365	1	Moisture Sensor Assembly
11	851374	1	Galvanized Tumbler Assembly
	851557	1	Stainless Steel Tumbler Assembly
	115909	1	Rear Tumbler Felt ... Not Illustrated
12	102415	1	15 Rib Drive Belt
13	887256	1	Non-Coin Front Support Panel with Auto (black)
	887257	1	Coin Front Support Panel (black)
14	851274*	1	Main Door Assembly with Handle (painted)
	851272	1	Main Door Assembly with Handle (stainless steel)
	103067	3	Door Hinge ... Not Illustrated
15	170233*	1	Main Door Handle
16	115911	1	Front Tumbler Felt
17	851384	1	Coin Vault
	819286	1	Coin Vault Jumper Harness ... Not Illustrated
18	125916	1	Coin Box with 2 Keys (each lock keyed different)
19	154059	4	U-Nut Retainer
20	154364	4	#10-16 x 1/2" Phillips Truss Head Screw
21	851529	2	Front Wheel Bracket Assembly (refer to Tumbler Wheel Assembly on page 19)
	102397	1	Door Gasket

* Specify color when ordering.

Control Panel / Toe Panel

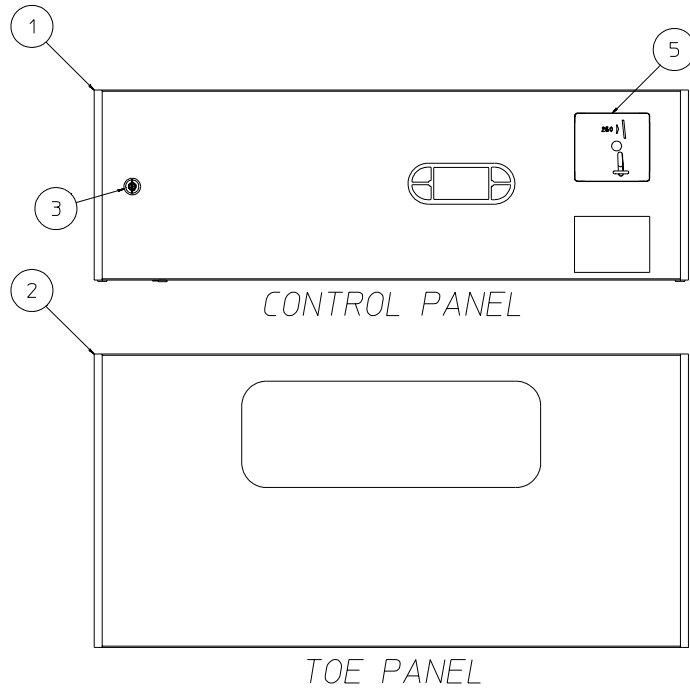

MAN7640A

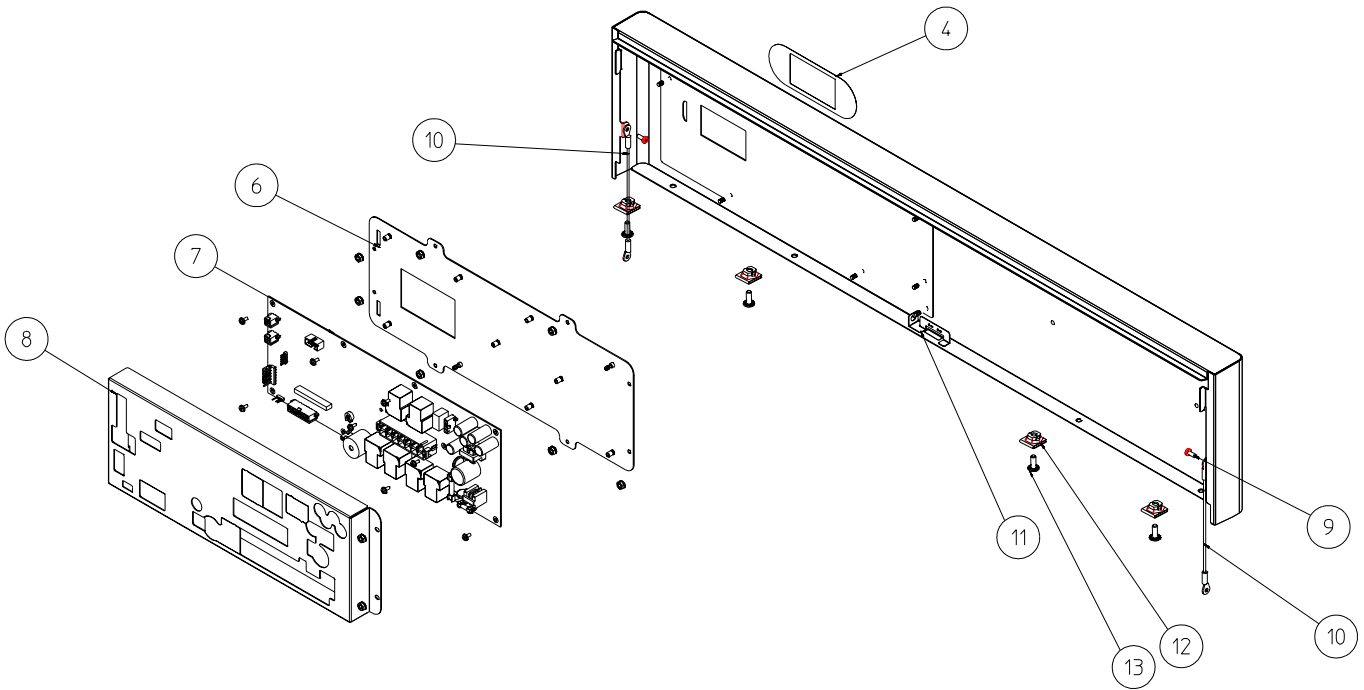

<u>Illus. No.</u>	<u>Part No.</u>	<u>Qty.</u>	<u>Description</u>
1	851522	1	Phase 8 Coin Control Panel Assembly Complete
	851518	1	Phase 8 Non-Coin Control Panel Assembly Complete
	851521	1	Phase 8 Coin Control Panel (panel Only)
	851517	1	Phase 8 Non-Coin Control Panel (panel Only)
2	814515*	1	Toe Panel (painted)
	814584	1	Toe Panel (stainless steel)
3	160071	1	XX4451 Lock Assembly
	160140	2	XX4451 Key
4	112587	1	Phase 8 Coin Keypad
	112586	1	Phase 8 Non-Coin Keypad
5	818213	1	25¢ Coin Acceptor Assembly with Optic Switch
	819264	1	Programmable Euro / UK Coin Acceptor
	887041	1	Optic Switch ONLY (for 25¢ coin acceptor)
6	819508	1	Control Mount Assembly
7	887092	1	Phase 8 Microprocessor without Fire Suppression System
	887093	1	Phase 8 Microprocessor with Fire Suppression System
	819541	1	Coin Block Jumper Harness (non-coin Only)
	136116	1	3-Amp Fuse
	136056	1	20-Amp Fuse
8	350250	1	Computer Board Cover
9	150331	2	#8-18 x 1/2" TORX® Screw
10	121530	2	Panel Support Cable (for coin models)
	350303	2	Panel Support Bracket (for non-coin models) ... Not Illustrated
11	819196	1	Main Door Switch Assembly
	813411	1	Door Switch Extension Harness ... Not Illustrated
12	154059	4	Tinnerman U-Nut Retainer
13	154364	4	#10-16 x 1/2" Phillips Truss Head Screw

* Specify color when ordering.

Rear Dryer Panel

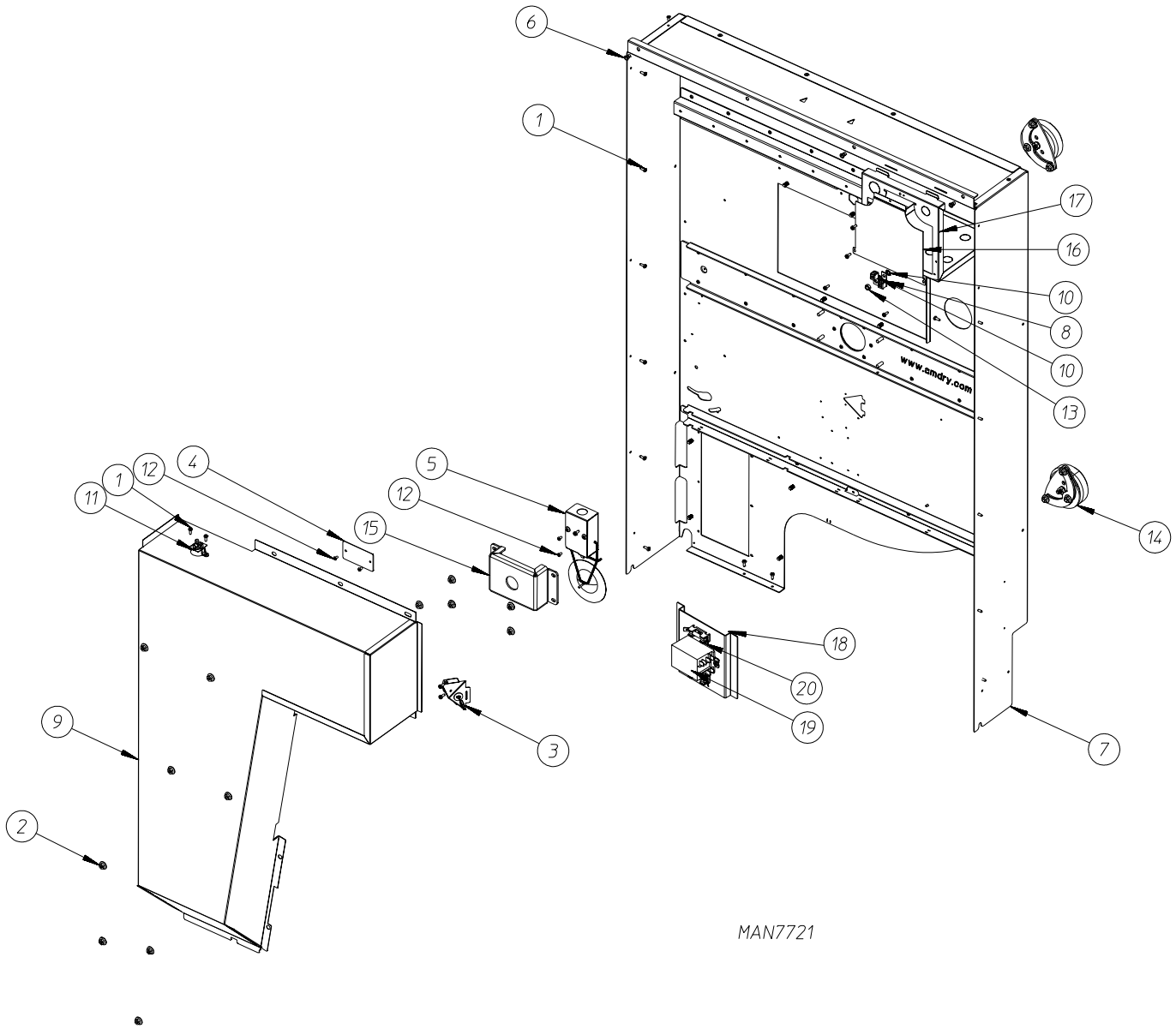

<u>Illus. No.</u>	<u>Part No.</u>	<u>Qty.</u>	<u>Description</u>
1	150331	22	#8-18 x 1/2" Pan Head TORX® Screw
2	152014	13	1/4-20 Serrated Hex Flange Nut
3	815207	1	Axial Probe Assembly
4	318691	1	Cover Plate for Models without S.A.F.E.
5	818570	1	Single Sail Switch Assembly (refer to Sail Switch Assembly on page 16)
6	152111	3	#10-32 Hex Body Rivnut
7	825961		Rear Tumbler Support Panel Complete (gas and electric) (includes illus. nos. 1 through 17)
	822114		Rear Tumbler Support Complete with Steam Coil (steam) (includes illus. nos. 1 through 4, 6 through 8, 10, 12 through 17)
8	121010	2	L70 14-4 Terminal Lug
9	851262	1	Heat Duct
10	153021	2	1/4" Star Washer
11	183112	1	205° Gas Hi-Limit Thermostat
12	154200	2	5/32" Pop Rivet
13	152002	1	1/4-20 Hex Nut
14	851530	2	Rear Wheel Bracket Assembly (refer to Tumbler Wheel Assembly on page 19)
15	350228	1	Thrust Bearing Box
16	350238	1	Electric Box Cover Plate
17	319653	1	Rear Electric Box
	120701	1	Gas and Steam Main Terminal Block ... Not Illustrated
	120699	1	Electric Main Terminal Block ... Not Illustrated
	120698	1	Electric Main Terminal Block Insulator ... Not Illustrated
18	801344	1	Split Phase Relay Assembly 208-240 Volt (includes illus. nos 18 through 20)
	319562	1	Split Phase Bracket
19	136056	2	20-Amp Fuse
20	131818	1	25-Amp Relay 208-240 Volt

Lint Box / Lint Screen

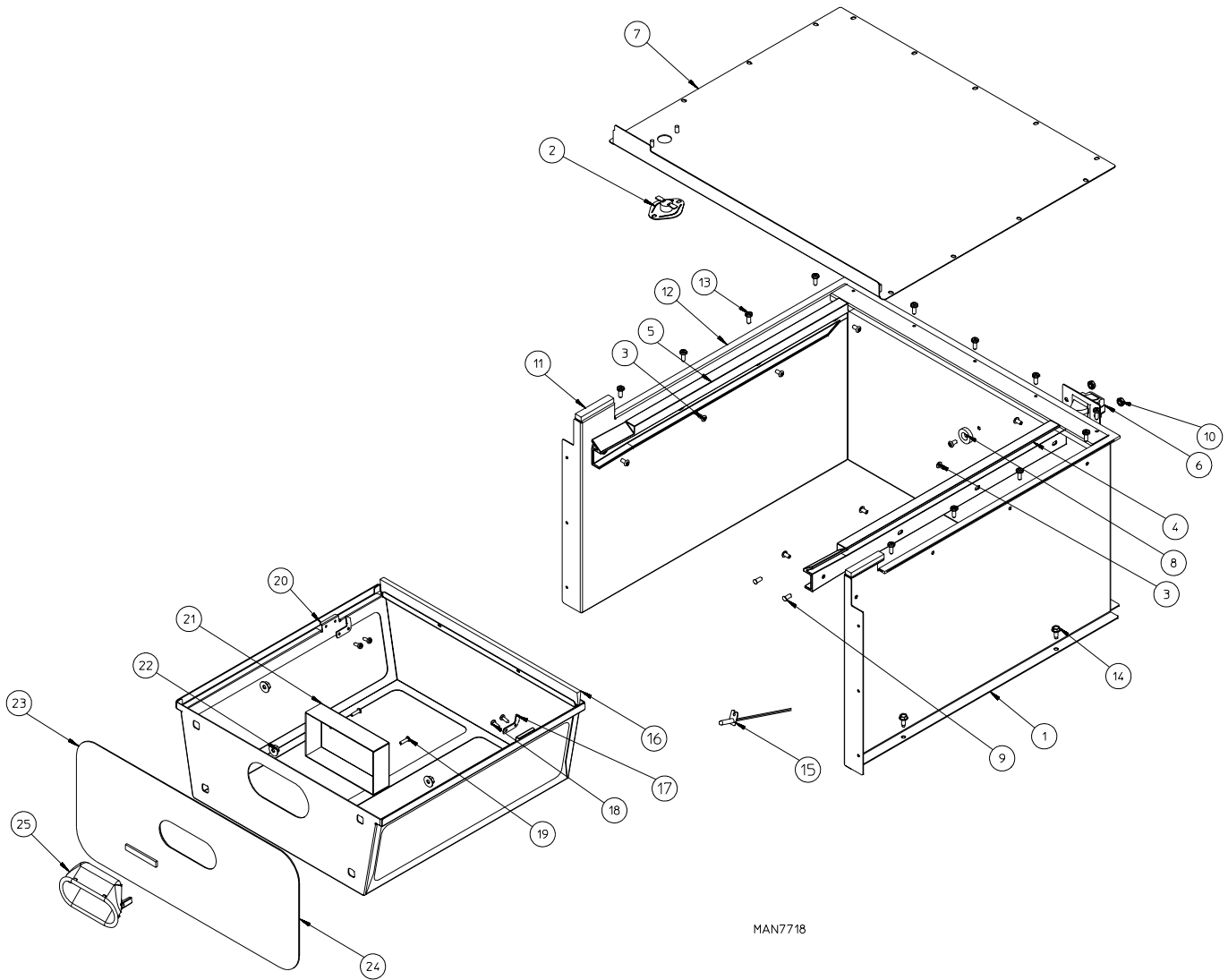

<u>Illus. No.</u>	<u>Part No.</u>	<u>Qty.</u>	<u>Description</u>
1	814513	1	Large Lint Box Assembly Complete (includes illus. nos. 1 through 15)
2	130119	1	190° Thermostat
3	154200	9	#5-32 Pop Rivet
4	185215	1	Lint Drawer Rail Right Side
5	185216	1	Lint Drawer Rail Left Side
6	819523	1	Lint Drawer Switch Assembly
	122002	1	Lint Drawer Switch ONLY
7	814514	1	Lint Box Top Assembly
8	102004	1	0.75 Round Magnet
9	153564	2	#8-32 x 0.375 Clinch Stud
10	153073	2	#8-32 Keps Nut
11	117607	2	1/4" x 3/8" Sponge Tape (sold by the foot)
12	117604	1	1/8" x 3/8" Sponge Tape (sold by the foot)
13	150331	13	#8-18 x 0.5 TORX® Screw
14	150300	7	#10-16 x 0.75 Hex Washer
15	836028	1	Exhaust Temperature Probe
	151000	1	Pal Nut ... Not Illustrated
16	170171	1	Lint Drawer Brush
17	185423	2	Lint Drawer Stop
18	150331	4	#8-18 x 0.5 TORX® Screw
19	150334	2	#8-16 x 19/32" Phillips Screw
20	814577*	1	Lint Drawer Assembly Complete (painted)
	814581	1	Lint Drawer Assembly Complete (stainless steel)
	814576	1	Lint Drawer (no handle)
21	333693	1	Handle Cup
22	152014	4	1/4-20 Hex Flange Nut
23	814510*	1	Lint Drawer Handle (painted)
	814580	1	Lint Drawer Handle (stainless steel)
24	117604	1	Neo Sponge Tape
25	185148	1	Lint Drawer Handle

* Specify color when ordering.

Blower Motor Assembly

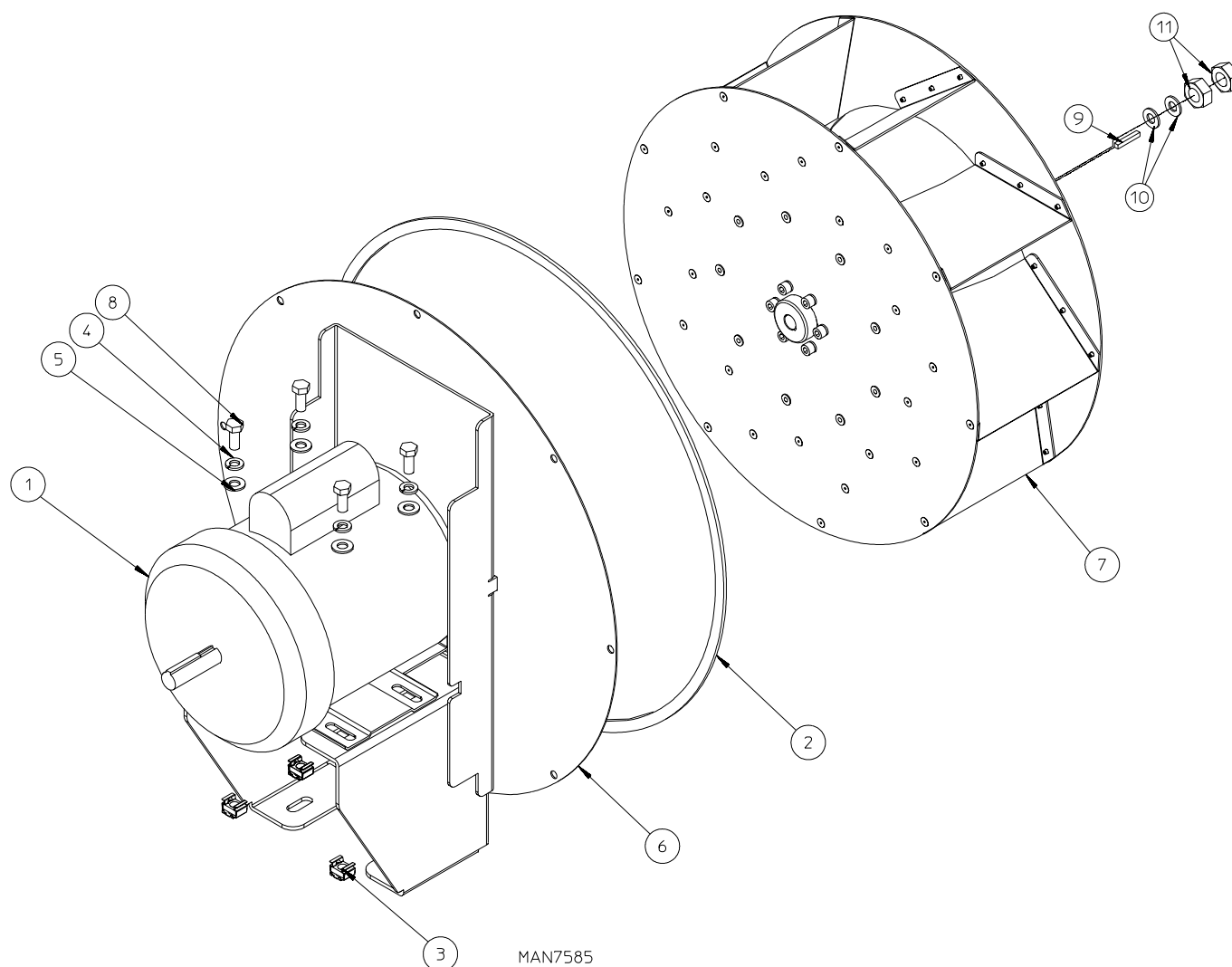

<u>Illus. No.</u>	<u>Part No.</u>	<u>Qty.</u>	<u>Description</u>
1	834723	1	Large Blower Motor Assembly Complete (60 Hz)
	100069	1	3/4 hp Blower Motor (60 Hz)
	819825	1	Large Blower Motor Assembly (50 Hz)
	100068	1	3/4 hp Blower Motor (50 Hz)
2	117604	2	1/8" x 3/8" Sponge Tape (sold by the foot)
3	154000	5	5/16-18 Tinnerman Clip
4	153002	4	5/16" Lock Washer
5	153001	4	5/16" Flat Washer
6	834724	1	Large Motor Mount
7	822364	1	16" Riveted Impellor (1/2" Bore)
8	150501	4	5/16-18 x 3/4" Hex Bolt
9	100702	1	1/8" x 1/8" x 1-1/2" Key
10	153050	2	1/2" S.A.F.E. Flat Washer
11	152006	2	1/2-20 Left-Hand Jam Nut

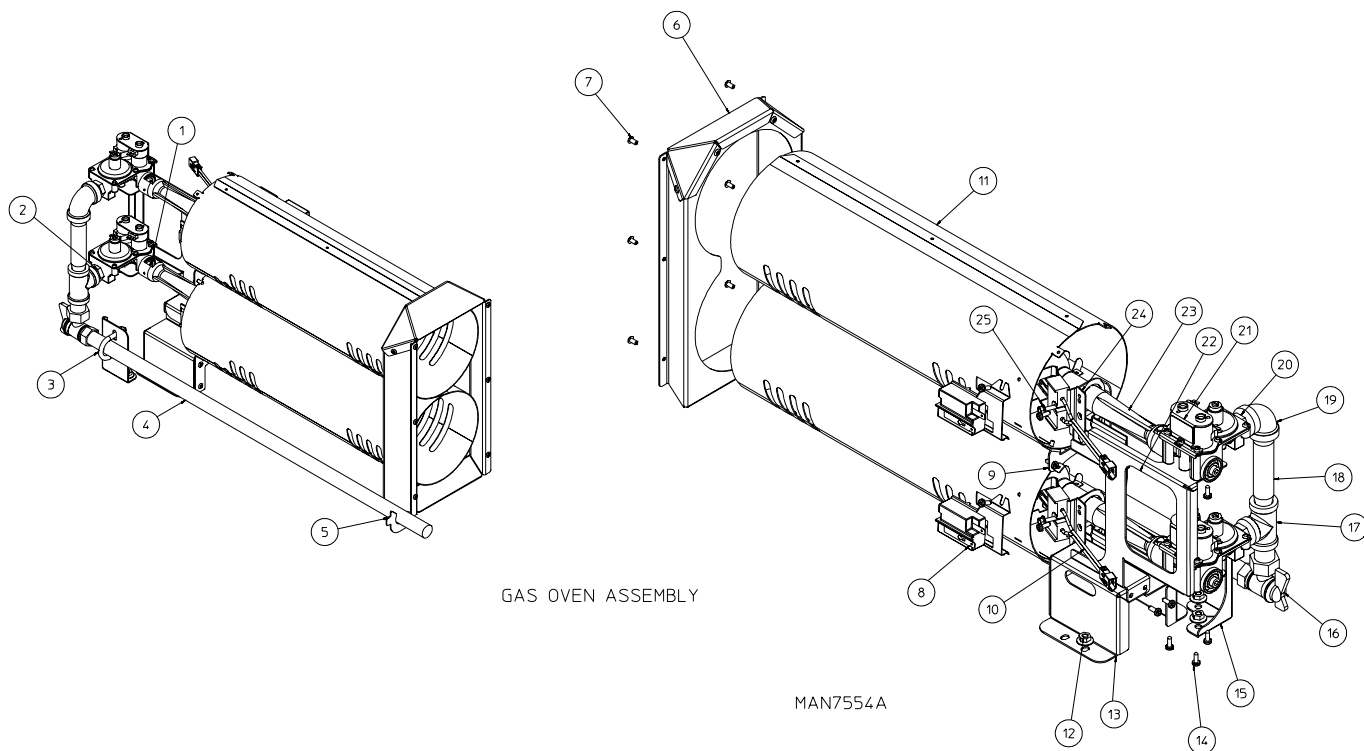

Illus. No.	Part No.	Qty.	Description
1*	140880	2	#22 Orifice Natural Gas
	140905	2	#44 Orifice Liquid Propane
	884249	1	Liquid Propane Conversion Kit
2	183137	2	3/8" Close Nipple Black Iron
3	154355	1	U-Bolt with Nuts for 1/2" Black Pipe
4	143351	1	1/2" x 31-3/4" Black Pipe
5	350226	1	Rear Gas Pipe Support
6	851387	1	Burner Funnel Transition Assembly
7	154200	14	5/32" Pop Rivet
8	130500	2	Radiant Heat Sensor
9	350217	1	Burner Funnel Top Lip Bracket
10	128910	2	Hot Surface Ignitor
11	815116	1	60 Hz Natural Gas Dual Burner Assembly
	884372	1	60 Hz Liquid Propane Gas Dual Burner Assembly
	350219	2	Round Gas Burner Funnel ONLY
12	152014	4	1/4-20 Free Spin Nut
13	350221	1	Dual Round Gas Burner Support Bracket
14	150331	19	#8-18 x 1/2" Pan Head TORX® Screw
15	350253	1	Front Gas Pipe Bracket
16	141321	1	Gas Shutoff Assembly
17	142820	1	1/2" x 1/2" x 1/2" Black Iron Tee
18	142703	1	1/2" x 4" Black Iron Pipe
19	142500	1	1/2-90° Elbow
20	142953	2	3/8" x 1/2" Steel Bushing
21	128944	2	25M Gas Valve 120 VAC 60 Hz
	128907	2	25M Gas Valve 120 VAC 50 Hz
22	350220	1	Dual Gas Valve Bracket
23	183144	2	In-Shot Tube
24	185063	2	Ignitor Bracket
25	183145	2	Hot Surface Ignitor Mounting Screw

* Consult factory for elevation over 2,000 feet for correct burner orifice size.

Steam Coil / Electric Oven Assembly

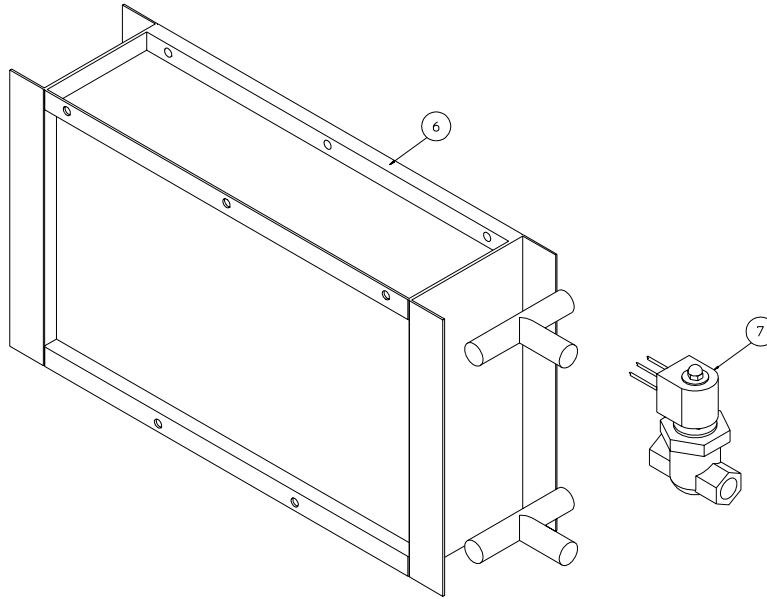

STEAM COIL ASSEMBLY

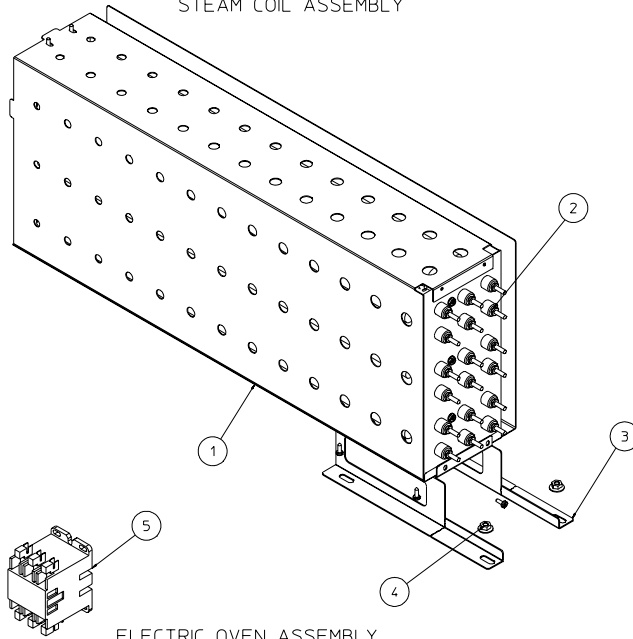

ELECTRIC OVEN ASSEMBLY

MAN7555A

<u>Illus. No.</u>	<u>Part No.</u>	<u>Qty.</u>	<u>Description</u>
1	851396	1	Electric Oven Assembly 200-415V
2	119997	1	22 kW Element
3	350230	1	Electric Oven Support Bracket
4	152014	2	Free Spin Wash Nut
5	131322	1	208/240V 30A Contactor 50/60 Hz
	131324	1	208/240V 40A Contactor 50/60 Hz
	131326	1	208/240V 50A Contactor 50/60 Hz
	131328	1	208/240V 60A Contactor 50/60 Hz
	131330	1	208/240V 75A Contactor 50/60 Hz
6	165067	1	Copper Steam Coil
7	813415	1	Steam Solenoid 120V (60 Hz)
	813416	1	Steam Solenoid 220-240V (50/60 Hz)

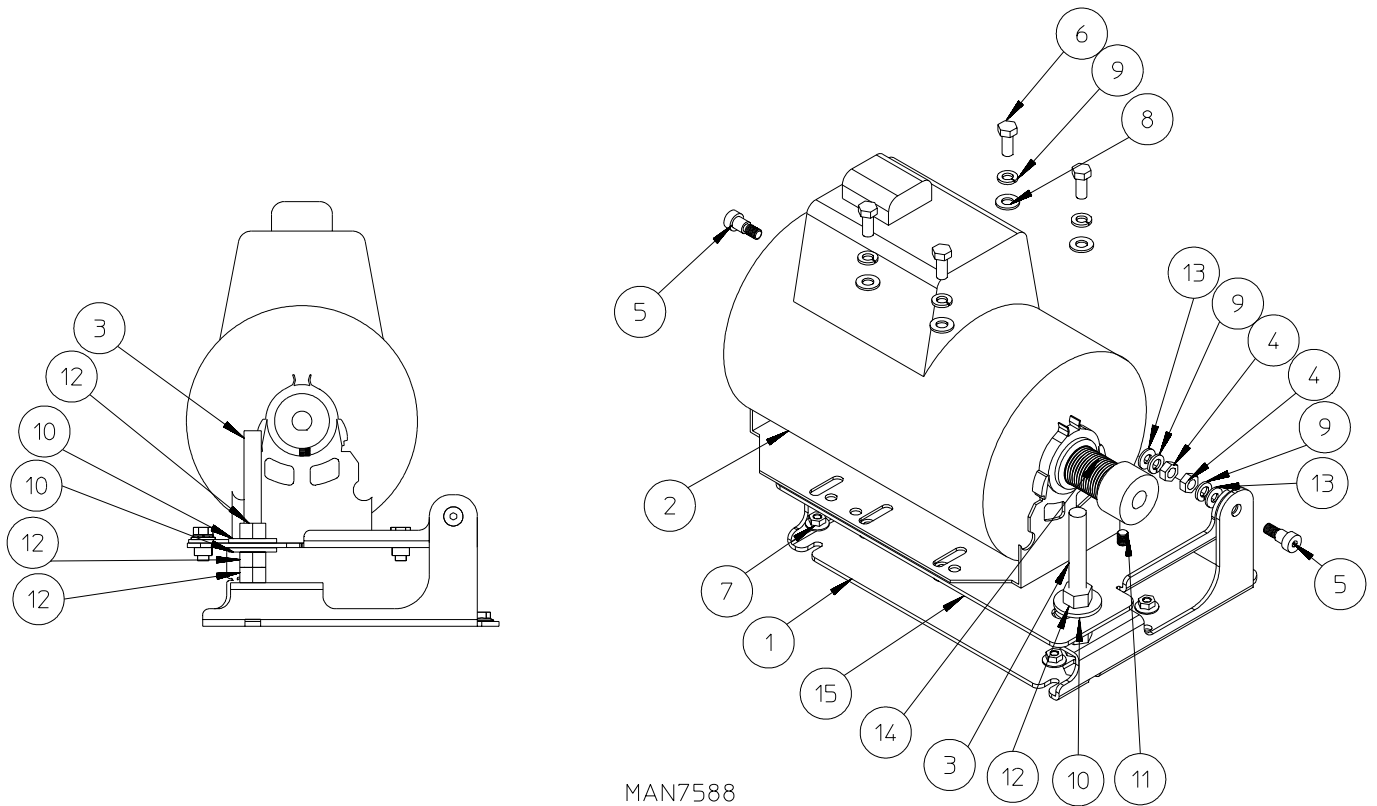

MAN7588

<u>Illus. No.</u>	<u>Part No.</u>	<u>Qty.</u>	<u>Description</u>
1	350301	1	Motor Mount Base Plate
2	815250	1	Drive Motor Assembly Complete (60 Hz)
	887221	1	Drive Motor with Sheave (60 Hz)
	819824	1	Drive Motor Assembly Complete (50 Hz)
	887222	1	Drive Motor with Sheave (50 Hz)
3	150609	1	1/2-13 x 4-1/2" Tap Bolt
4	152004	2	5/16-18 Hex Nut
5	154266	2	3/8" x 3/8" Shoulder Screw
6	150501	4	5/16-18 x 3/4" Tap Bolt Hex Head
7	152014	5	1/4-20 Free Spin Wash Nut
8	153001	4	5/16" Flat Washer
9	153002	6	5/16" Split Lock Washer
10	153033	2	1/2" x 1-3/8" Flat Washer
11	154321	1	5/16-24 x 3/8" Alan Setscrew
12	152011	3	1/2-13 Hex Nut
13	153018	2	1/4" Flat Washer
14	323373	1	60 Hz Motor Sheave
	350004	1	50 Hz Motor Sheave
15	851543	1	Motor Platform Assembly
	102415	1	15 Rib Drive Belt ... Not Illustrated

Sail Switch Assembly

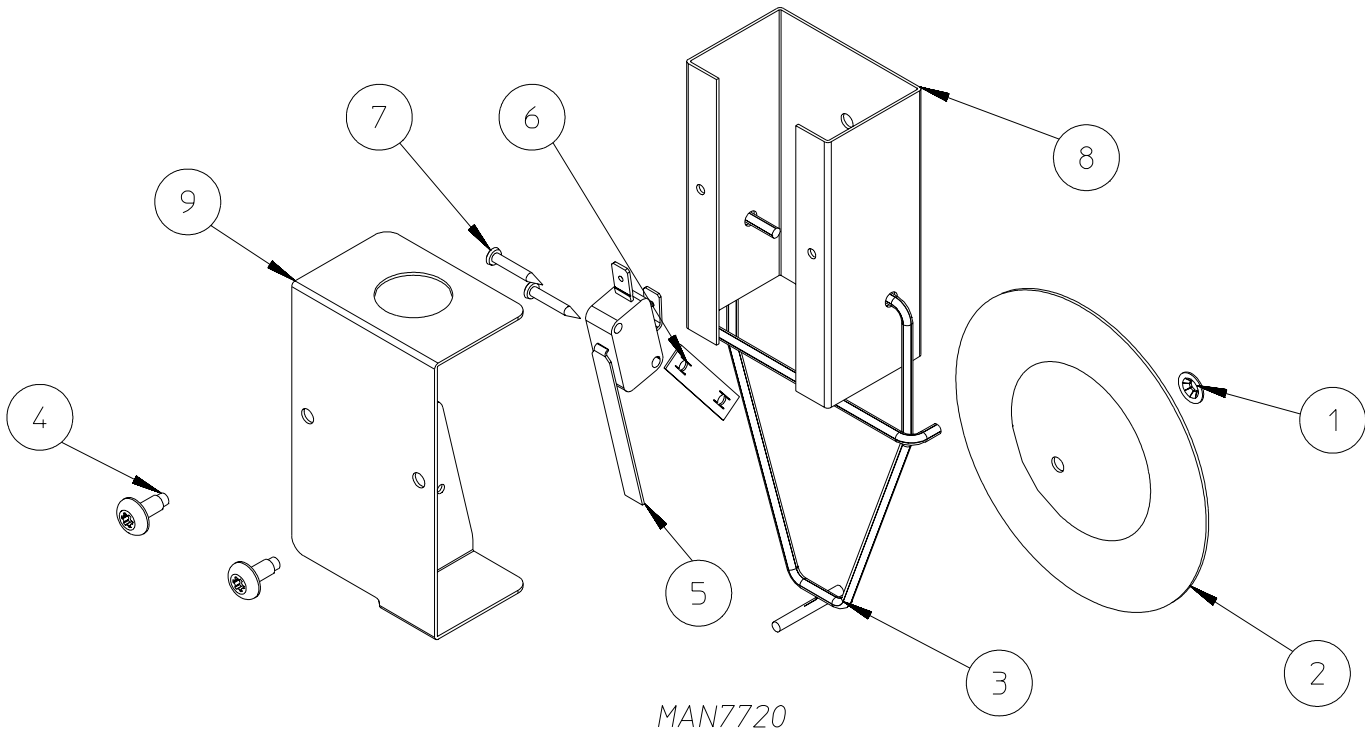

<u>Illus. No.</u>	<u>Part No.</u>	<u>Qty.</u>	<u>Description</u>
1	154002	1	1/8" Push-On Fastener
2	319206	1	Sail Switch Damper (embossed)
3	105500	1	Sail Switch Actuator Rod
4	150313	2	#10-16 x 1/2" TORX Plus® Screw
5	122200	1	Sail Switch
6	154004	1	Speed Nut
7	150303	2	#4 x 3/4" Phillips Screw
8	318237	1	Sail Switch Box
	818570	1	Sail Switch Assembly (includes illus. nos. 1 through 9)
9	350283	1	Sail Switch Box Cover

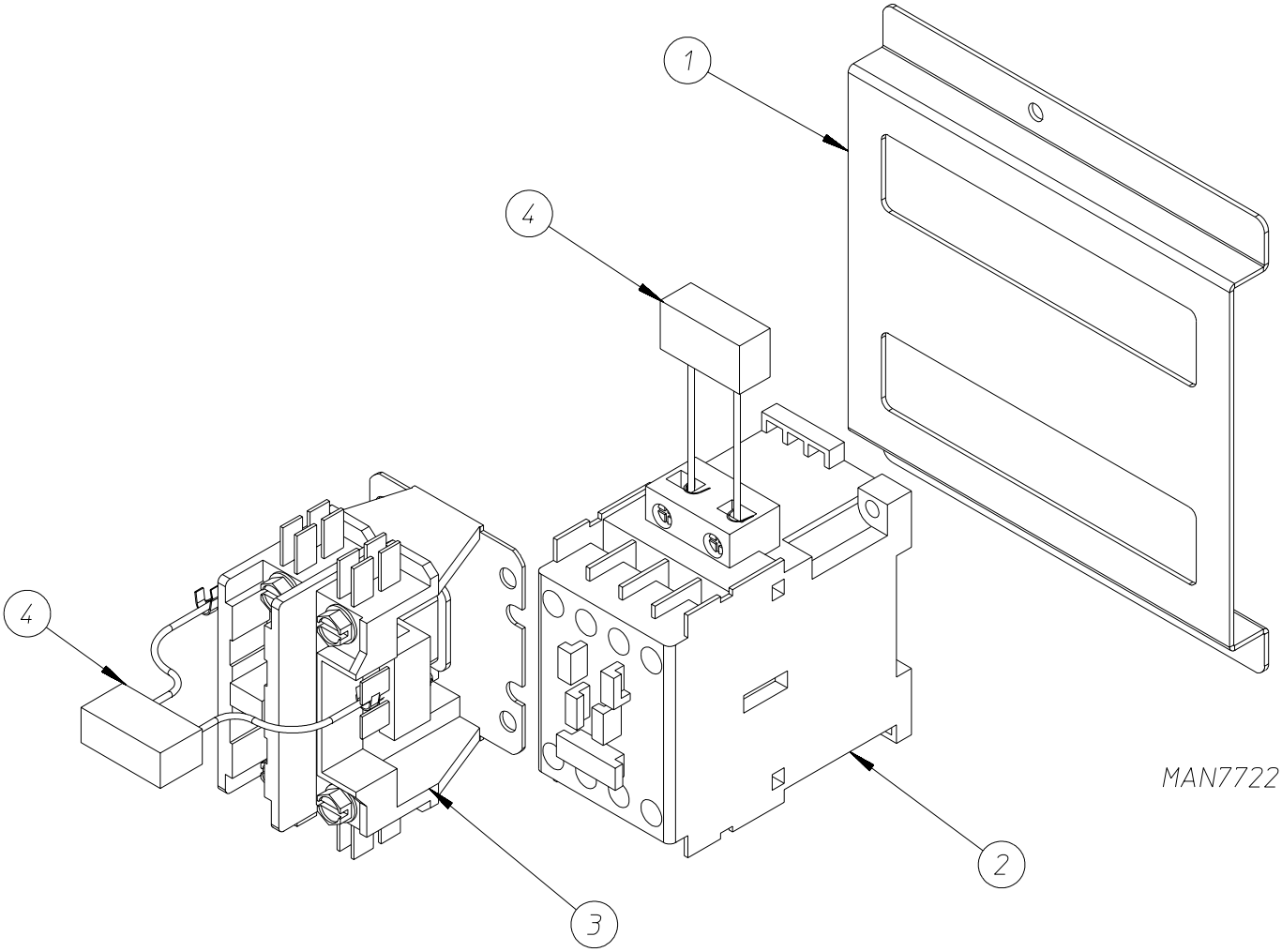

MAN7722

<u>Illus. No.</u>	<u>Part No.</u>	<u>Qty.</u>	<u>Description</u>
1	317052	1	Contactor Bracket
2	132414	1	Reversing Contactor 120V
	131818	1	Reversing Relay 208-240V
3	132652	1	Blower Contactor 120V
4	824828	2	RC Network

Fire Suppression System

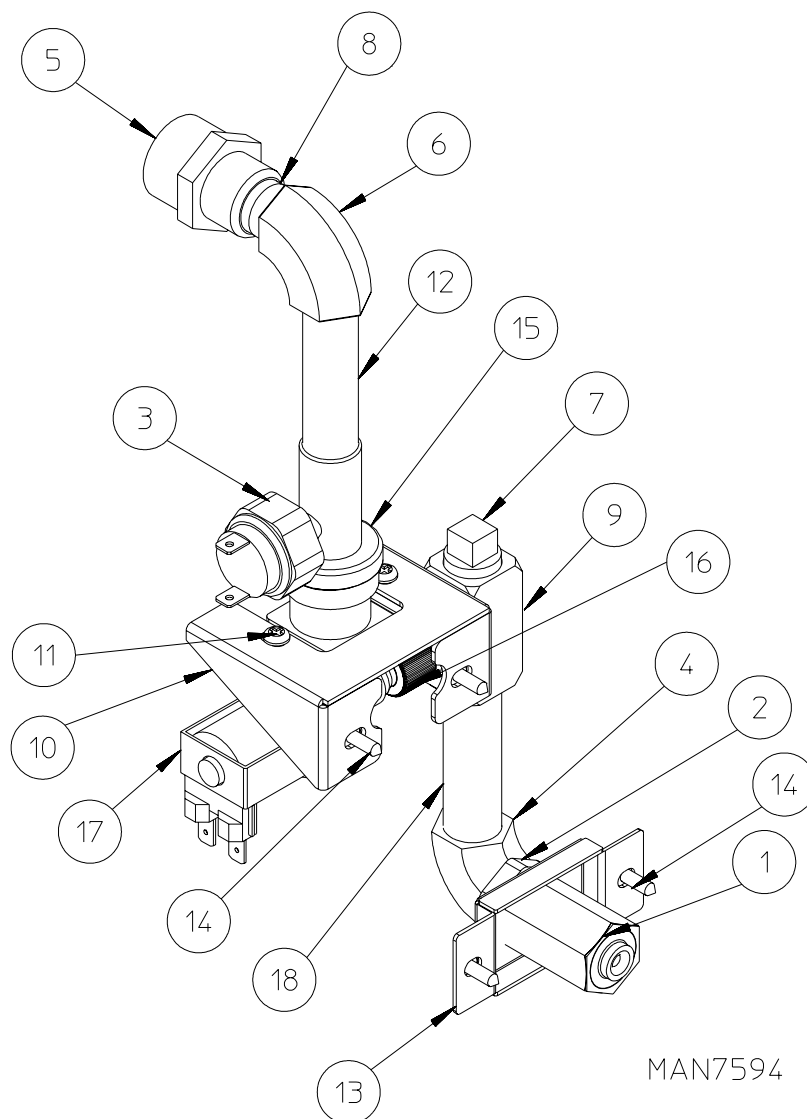

MAN7594

<u>Illus. No.</u>	<u>Part No.</u>	<u>Qty.</u>	<u>Description</u>
1	143581	1	3 GPM 3/8" N.P.T. Spray Nozzle
2	143303	1	3/8" N.P.T. Brass Lock Nut
3	136987	1	Water Jet Pressure Switch
4	143155	1	3/8" Brass Street Elbow
5	143025	1	3/4-11 NH x 3/8" N.P.T. Nylon Hose Adapter
6	143310	1	3/8" Brass 90° Elbow
7	143251	1	3/8" M.P.T. Brass Plug
8	143241	1	3/8" x Close Brass Nipple
9	143220	1	3/8" F.P.T. Brass Tee
10	319231	1	Water Valve Bracket
11	154338	2	M4 x 6mm Phillips Head Slotted Machine Screw
12	143242	1	3/8" x 2-1/2" Brass Nipple
13	318422	1	Spray Nozzle Bracket
14	150331	4	#8-18 x 1/2" Pan Head TORX® Screw
15	143182	1	3/4" GHT x 1/8" x 3/8" N.P.T. Brass Tee
16	143183	1	7/16-20 x 3/8" N.P.T. Brass Adapter
17	165120	1	Water Inlet Valve 24VDC
18	143323	1	3/8" x 3" Brass Nipple

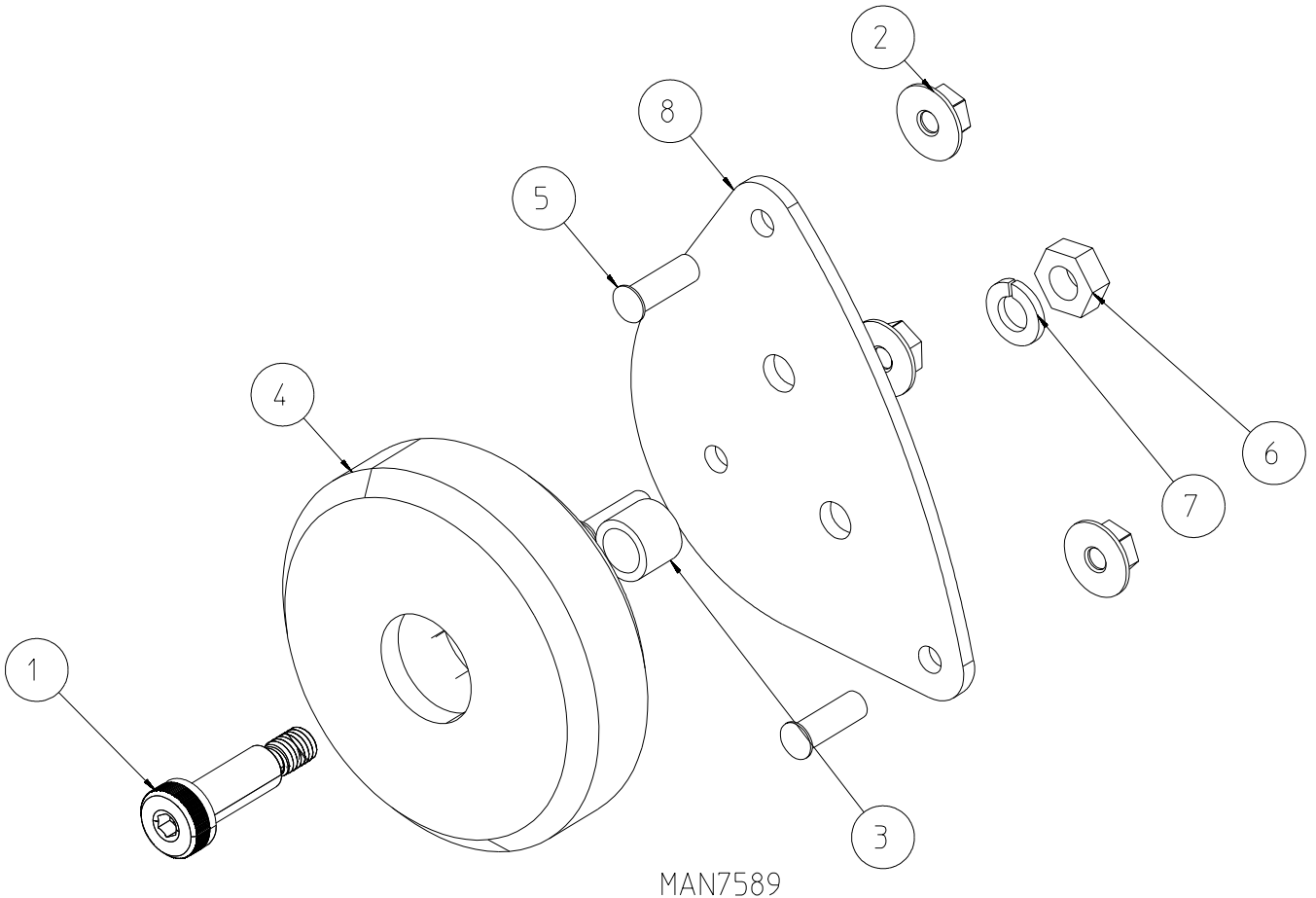

Illus. No.	Part No.	Qty.	Description
1	154264	1	10 M8 x 25mm Shoulder Bolt
2	152014	3	1/4-20 Free Spin Wash Nut
3	154284	1	Tumbler Wheel Spacer
4	180060	1	3-1/2" Tumbler Support Wheel
5	153557	3	1/4-20 x 3/4" Self-Clinching Stud
6	154013	1	M8 Hex Nut
7	153002	1	5/16" Lock Washer
8	350196	1	1/2" Wheel Bracket
	851529	1	Front Wheel Assembly Complete
	851530	1	Rear Wheel Assembly Complete ... Not Illustrated
	350198	2	Rear Wheel Bracket Shim ... Not Illustrated (rear Only)

Duplicate all parts for rear wheel assembly.

Transformer Assembly

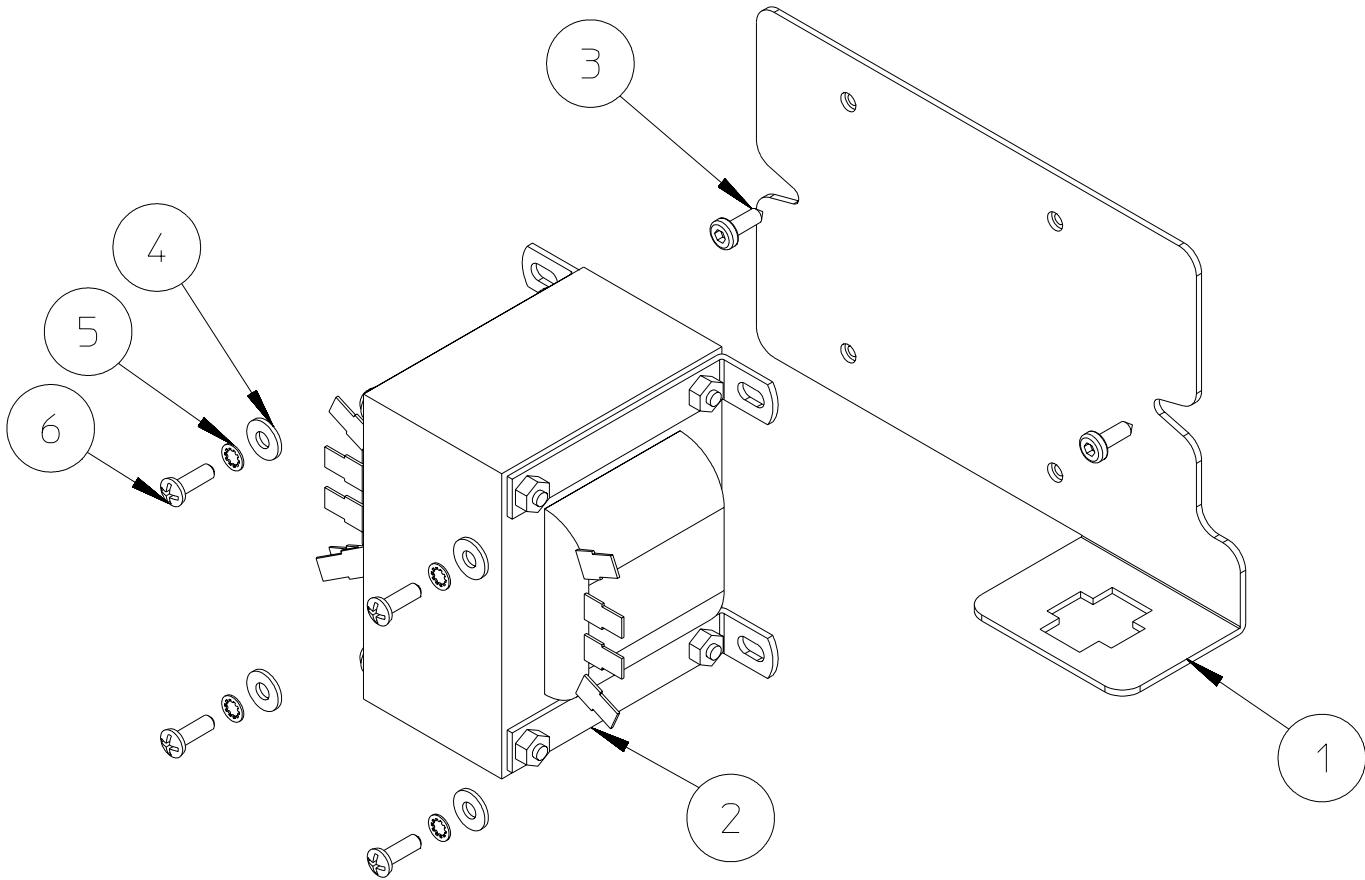

MAN7726

<u>Illus. No.</u>	<u>Part No.</u>	<u>Qty.</u>	<u>Description</u>
1	851451	1	Transformer Mounting Plate
2	132029	1	208-240 Volt to 120 Volt Auto Transformer
	851519	1	208-240 Volt to 120 Volt Transformer Assembly (includes illus. nos. 1 through 6)
3	150331	2	#8-18 x 1/2" Pan Head TORX® Screw
4	153000	4	#8 Flat Washer
5	153012	4	#8 Star Washer
6	150108	4	#8-32 x 1/2" Phillips Pan Head Screw

